

Your new "....."  
 lamp - by Maker &  
 The Earnest Workshop

**Assembly Instructions**

Items that you will find included:

6 x M6 Screws

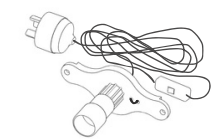

1 x Lampholder,  
 cord and switch

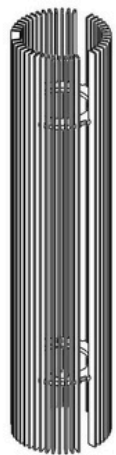

1 x Lamp shade

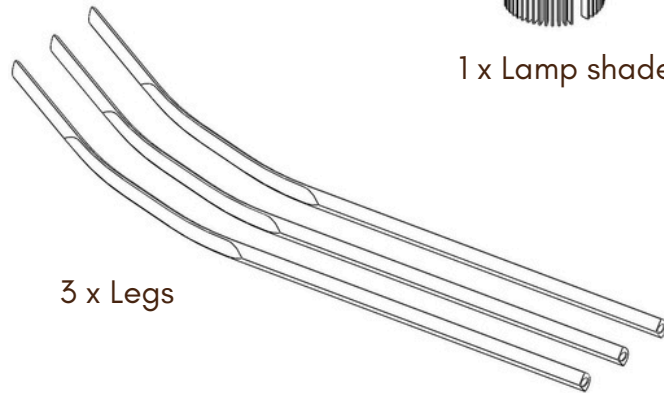

3 x Legs

**Step 1**

Place the two lamp cradles, included in the main box, on a flat surface and lower the lamp onto the circular cutout as shown, Position one of the three slat gaps at the top.

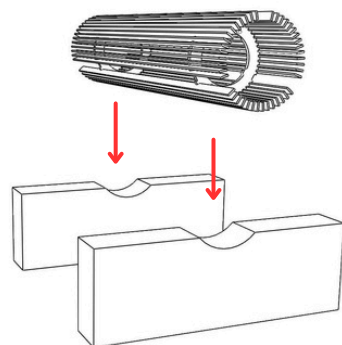

**Step 2**

Look at the two holes in the locations shown. One of these is colour coded. On the leg sections, find the hole that has the matching colour code and align it with the hole on the lamp. Lower it into place.

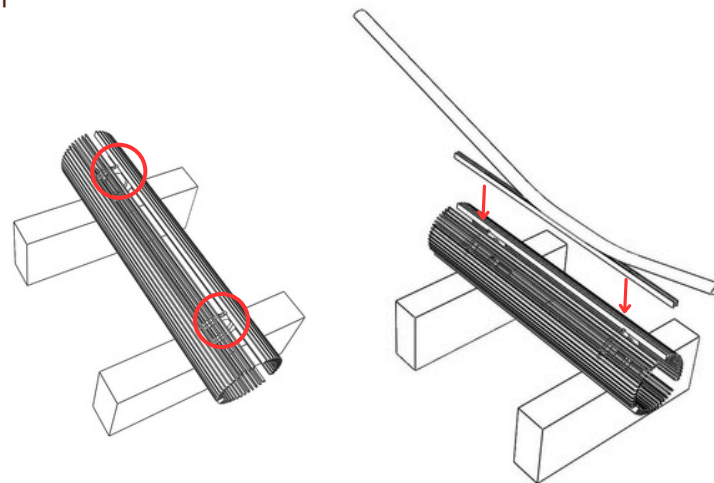

**Step 3**

Insert a screw into the colour coded hole from the inside of the lamp as shown and tighten it using the alley key provided. DO NOT over tighten the screw.

Repeat for the second hole on this leg

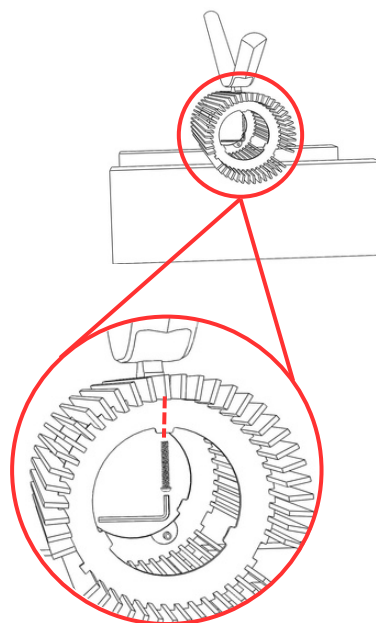

**Step 4**

Rotate the leg to one side until it rests on the cradles as shown.

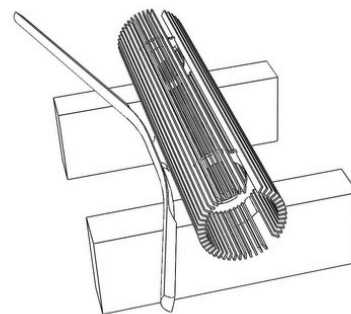

**Step 5**

Repeat Step 3 for assembly of the second leg.

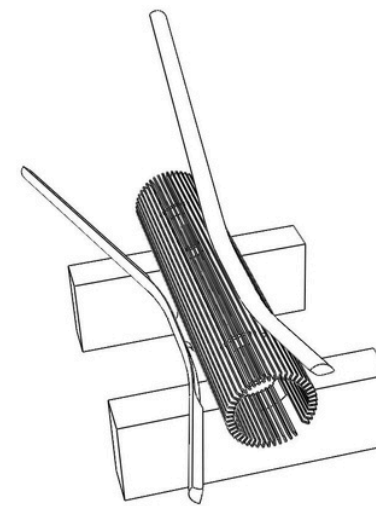

**Step 6**

Rotate the lamps so that the two legs are resting on the cradles as shown

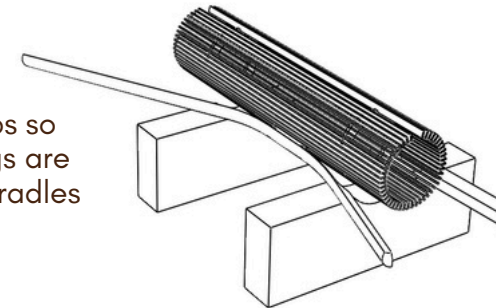

Repeat Step 3 for attachment of the third leg

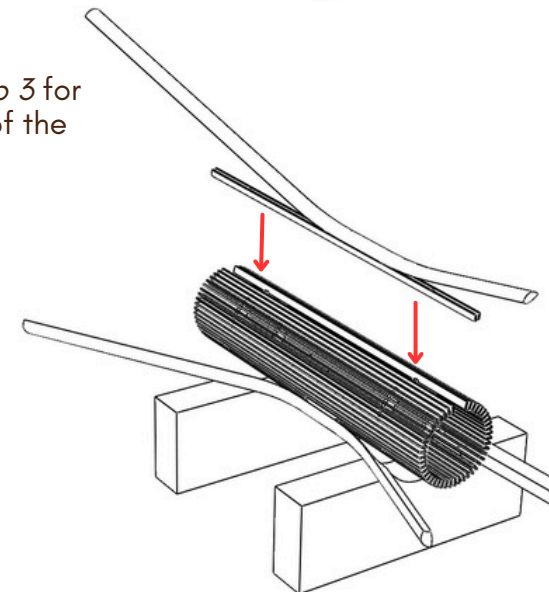

**Step 7**

Sit the assembled lamps up onto it's feet.



**Step 8**

**Attaching the lamp holder:**

Insert the recommended bulb into the lamp holder (see the "Care and Information" included)

Turn the lamp holder side on as shown so that it can fit up through the lower ring.

Once the lampholder is completely through the lower ring, turn it so that that the two holes align with the dowel / pegs on the lower ring as shown.

Lower the lamp holder down onto the dowel / pegs and press it on firmly.

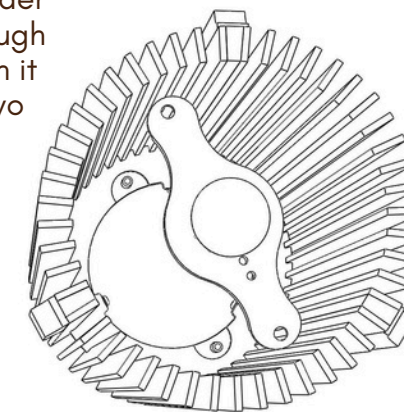
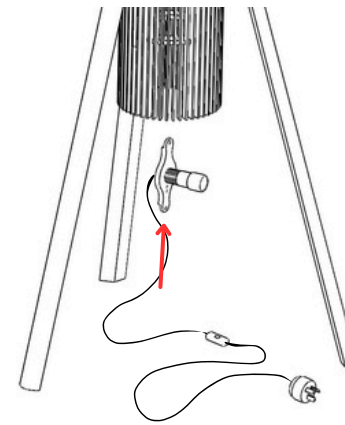

**Step 9**

Plug the lamp into power and turn the lamp on.

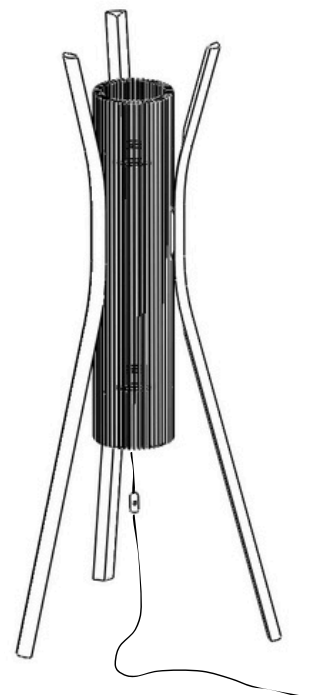

## Care instructions

Your Thanks for choosing one of our iO light fittings. Named after the mythical Greek princess who led Zeus astray with her beauty – also the fourth moon of Jupiter, a giver of light. I hope your new lamp adds both of these qualities to your environment.

Your iO light has been hand-made for you in our rural workshop near Tauranga, New Zealand.

**CARE: With minimal maintenance, your i light will look fantastic for a long, long time. Being of natural materials it will improve its look with age. But even iO lights are not immune to dust and insects, so from time to time you might want to freshen it up a little. Here's what we suggest:**

Your iO light is made using thin staves of plywood. For general cleaning I recommend dusting with a soft brush or duster. If the fins become marked you can wipe with a lightly dampened cloth. With exposure to daylight, all white woods will mellow over time taking on a 'honey' tone. If you want to freshen it up you can give the edges a quick gentle rub down with a fine (120 grit) sandpaper. The diffuser is made using traditional Japanese mulberry shoji paper with a hi-tech core. It can be wiped with a damp cloth occasionally if required.

## Electrical information

Nominal frequency in hertz: 50 Hz

For use indoors ta:25°C

If the external flexible cable or cord of this luminaire is damaged, it shall be exclusively replaced by the manufacturer or his service agent or a similar qualified person in order to avoid a hazard

Use only the recommended bulb rating  
B22 GLS 60W

Never use a bulb that is rated more than the recommended 60 Watt capacity.

Light bulbs become very hot in seconds. Do not attempt to touch the bulb while the lamp is lit and supervise others accordingly.

Before cleaning or replacing a defective bulb, switch off the lamp and unplug from the mains socket. Allow the bulb to cool for at least 10 minutes, before touching it and making the change.

Ensure the new bulb is secure in the holder before reconnecting to the power supply.