

HUSH OVAL E26

Designed by David Trubridge
(1018-D)

PLN GROUP

Overall Dimensions - Model: 1018-D (E26)

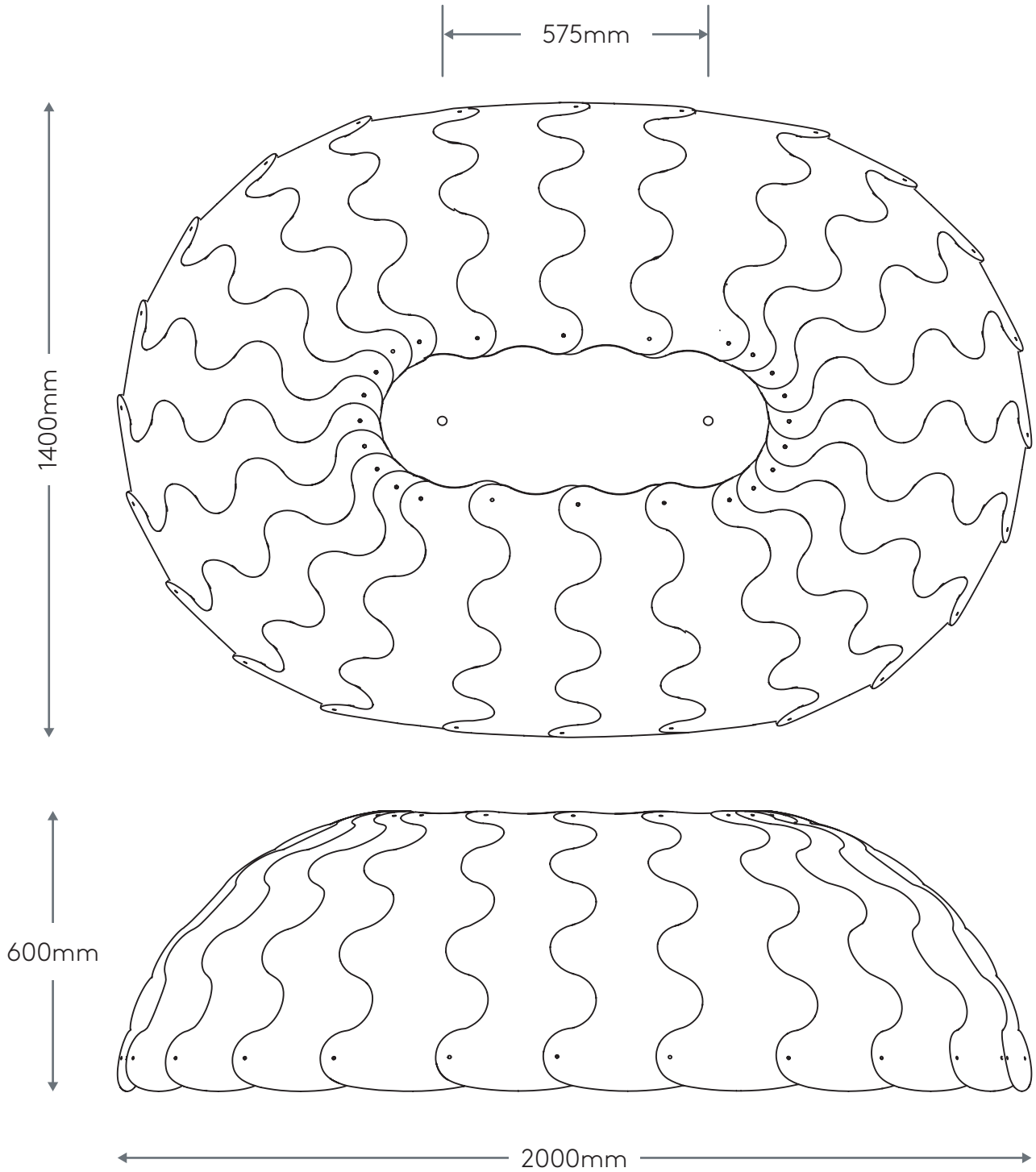

HUSH OVAL E26

Designed by David Trubridge
(1018-D)

PLN GROUP

Contents (not to scale)

Please double check all components are present and quantities are correct before beginning assembly

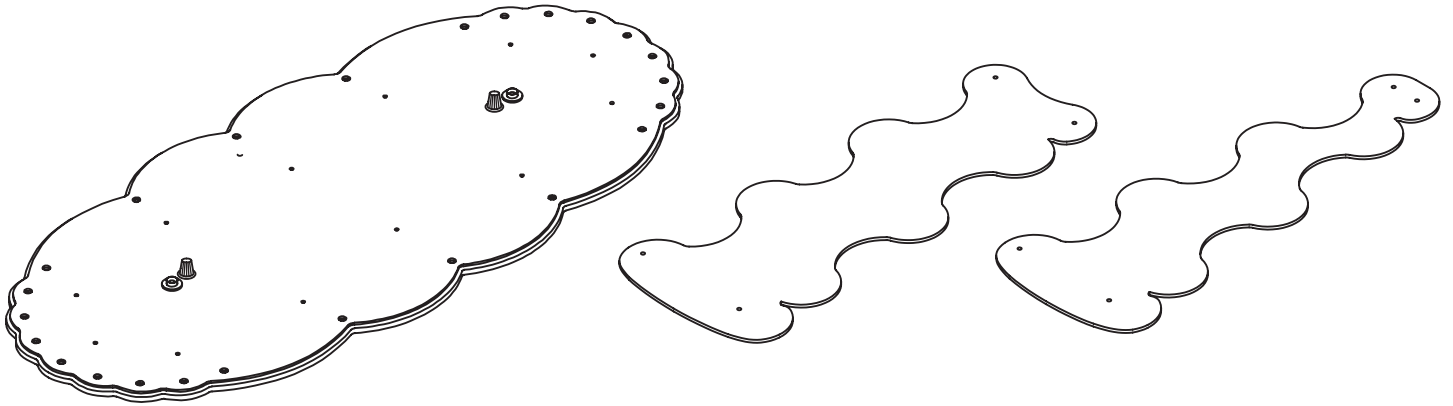

x1
Top Panel Assembly
(Cord set attached
but not shown)

x8
Straight
Felt Panels

x16
Tapered Felt Panels

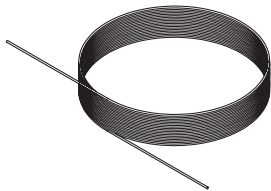

x2
2.1m Cable



x48 (+5)
Small Ratchet
Rivets (13mm)



x48 (+5)
Large Ratchet
Rivets (19mm)

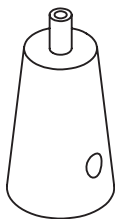

x2
Cone Gripper
without Base

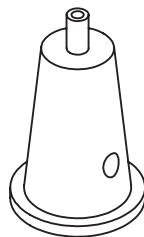

x2
Cone Gripper
with Base

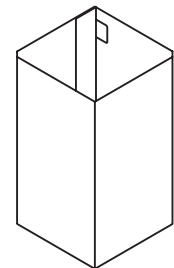

x2
Folded Cardboard
Pillars

Step 1 - Top Panel Ratchet Rivet Assembly

Screw on x2 Cone Grippers
(without bases)
onto base
already attached to top
panel assembly

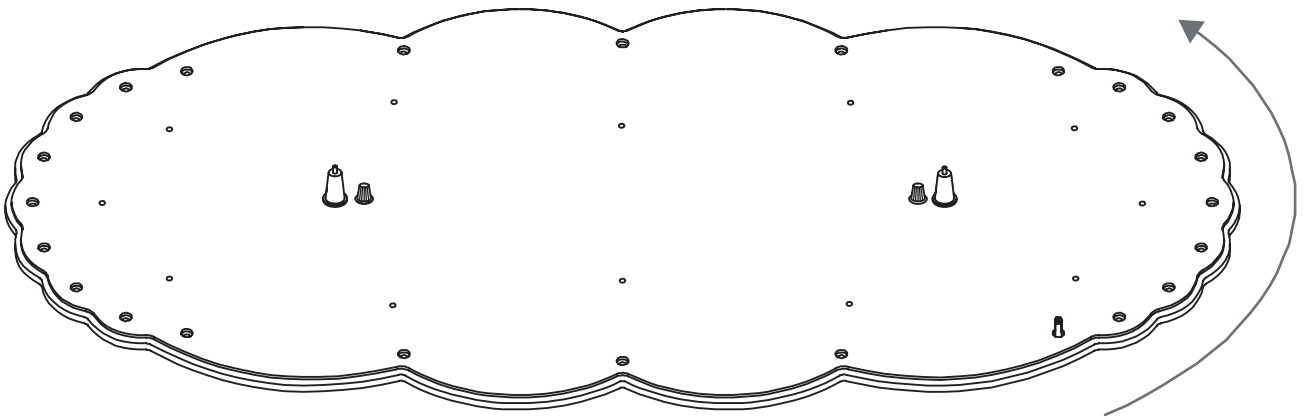
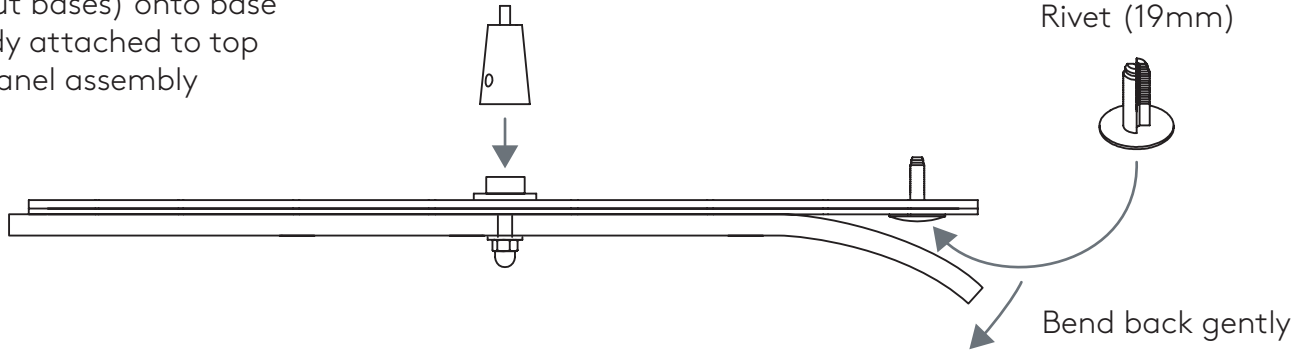

Insert Large Ratchet Rivets (19mm) in all holes around edge.

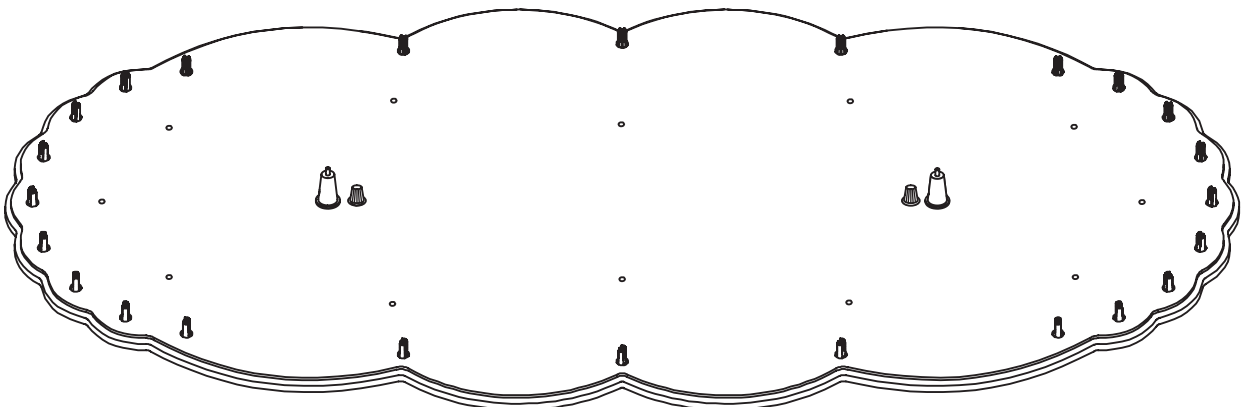

Step 2 - Pop out side panel plugs

Push out the 4 plugs per panel to make way for the plastic clips.

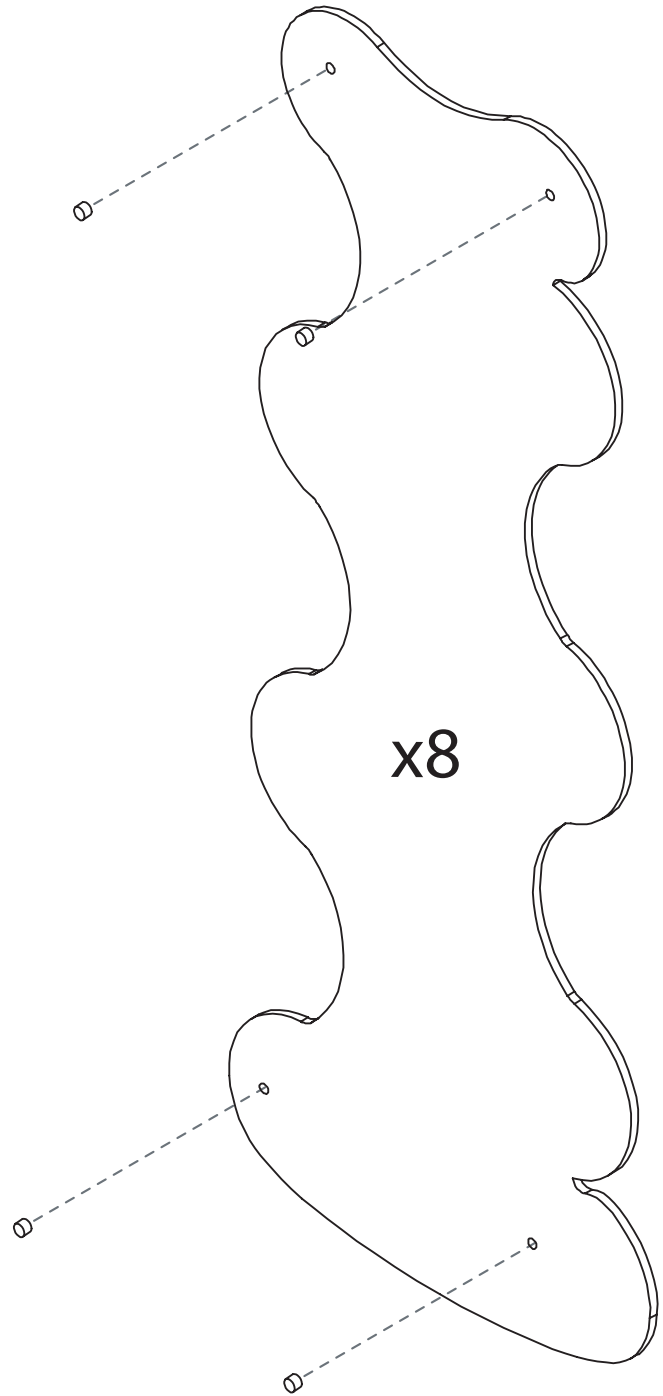
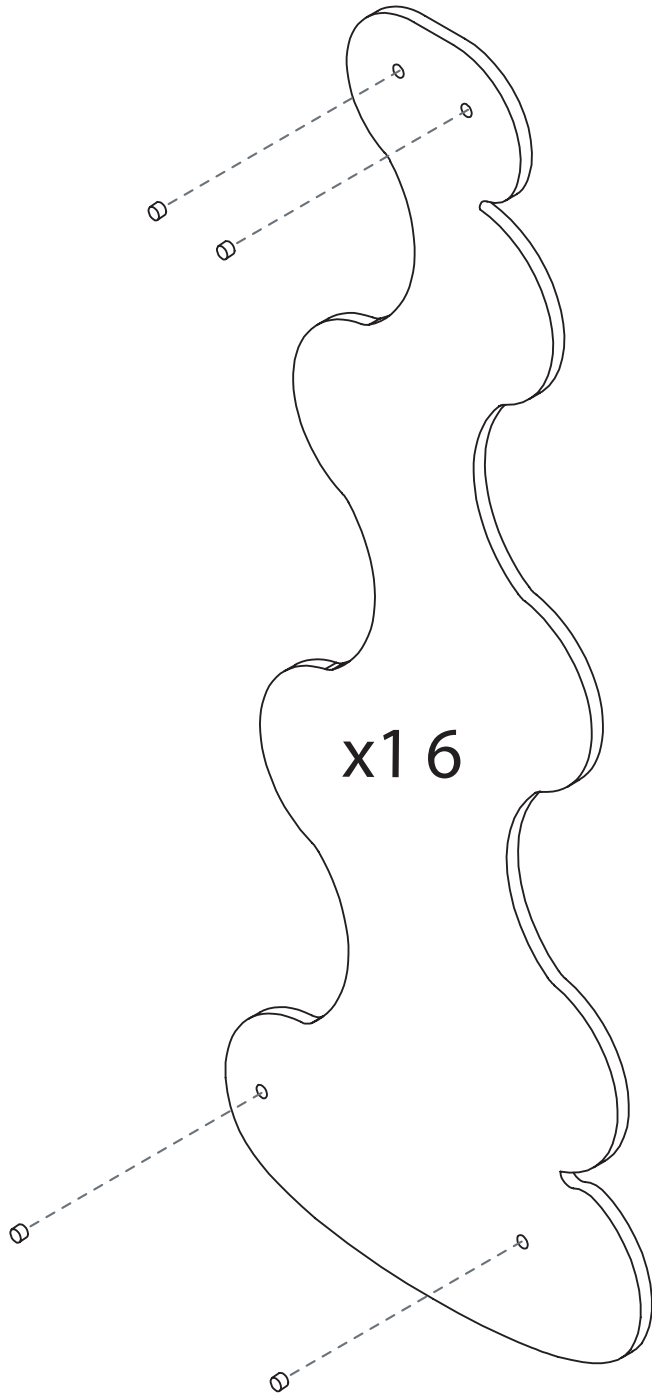

Step 3 - Top Panel to Side Panel Assembly

Assemble on a large clean surface or on floor.

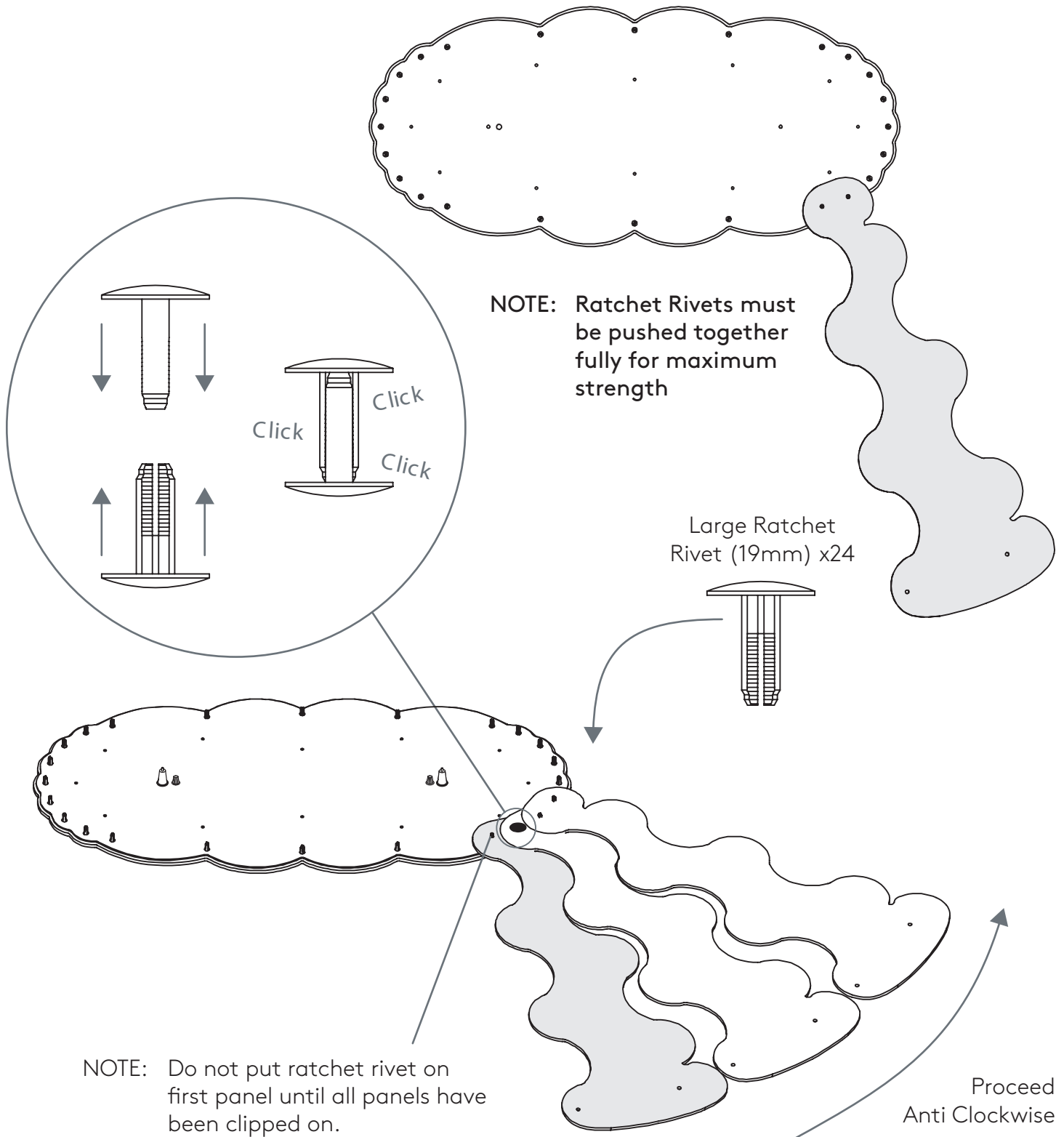

HUSH OVAL E26

Designed by David Trubridge
(1018-D)

PLN GROUP

Step 4 - Top Panel to Side Panel Assembly Continued

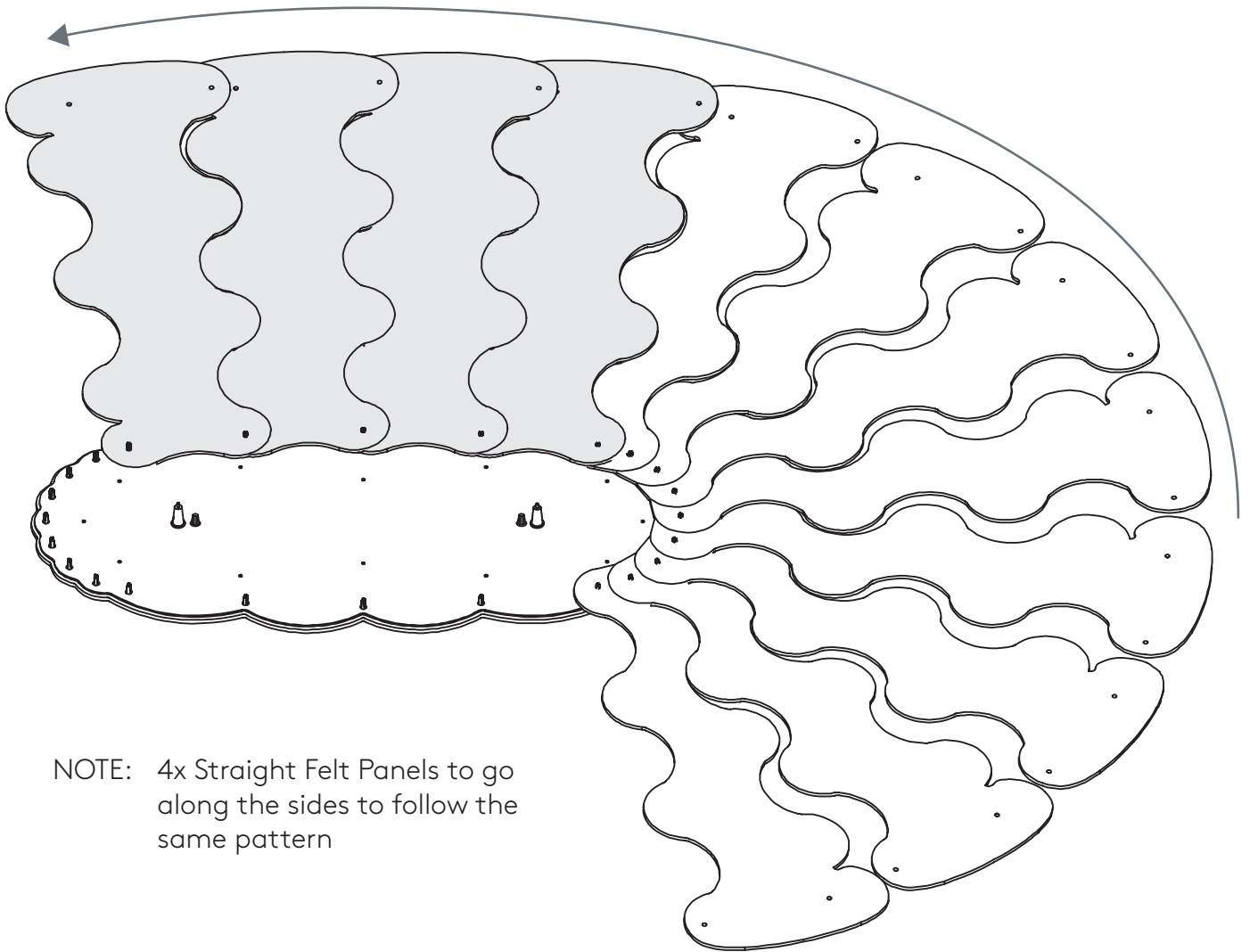

NOTE: 4x Straight Felt Panels to go along the sides to follow the same pattern

Step 4 - Top Panel to Side Panel Assembly Continued

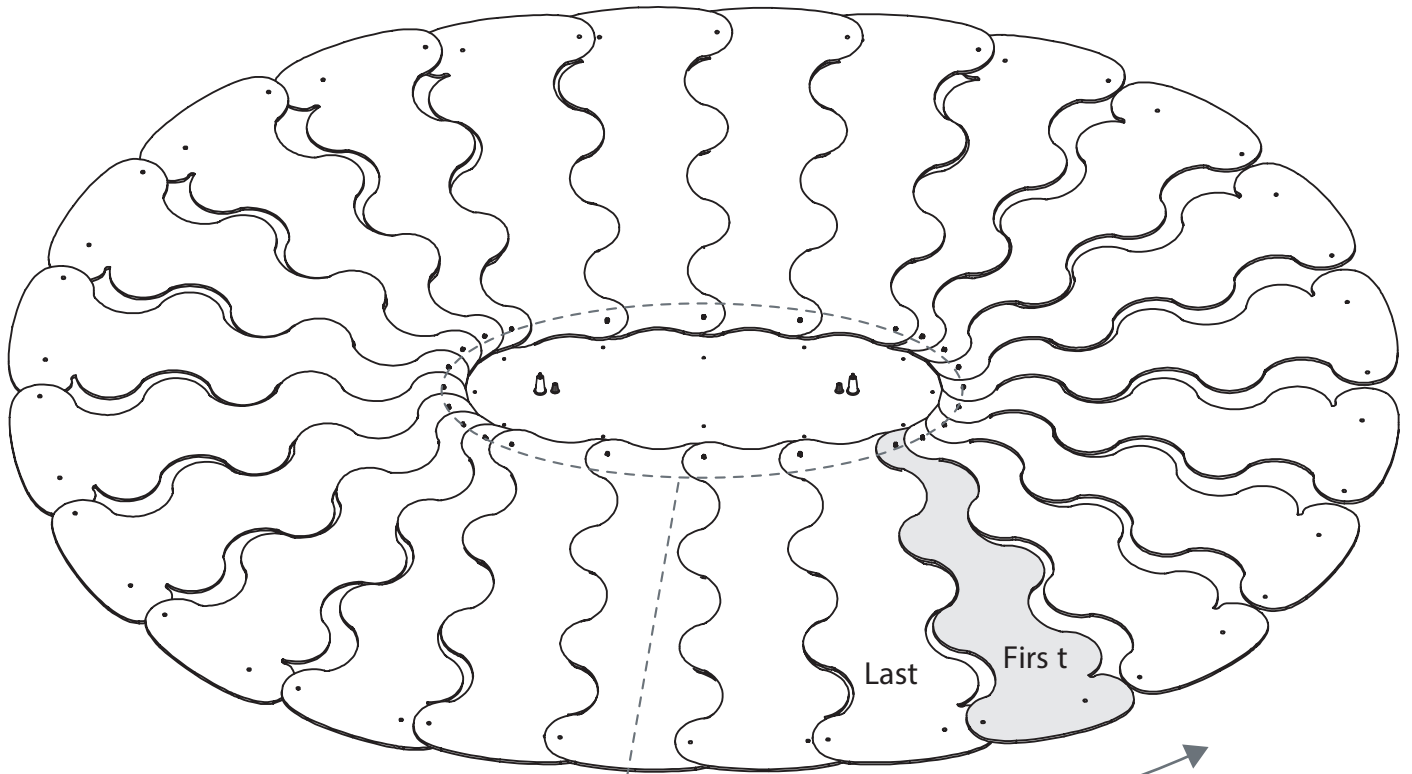

Tuck Last panel
under First panel
and clip together
with Large Ratchet
Rivet (19mm)

Cross Section Detail View of Top Panels overlapping.

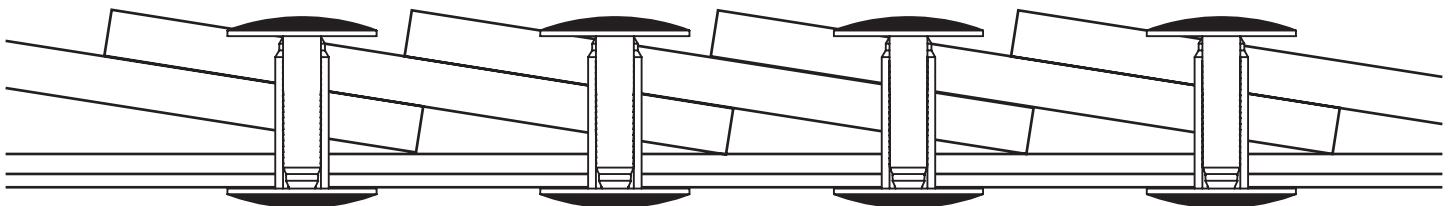

HUSH OVAL E26

Designed by David Trubridge
(1018-D)

Step 5 - Lifting into shape

Insert cables into Gripper Cones and use it to lift the Hush Oval approximately 600mm from the floor/surface.

The panels will begin to fall into their natural shape.

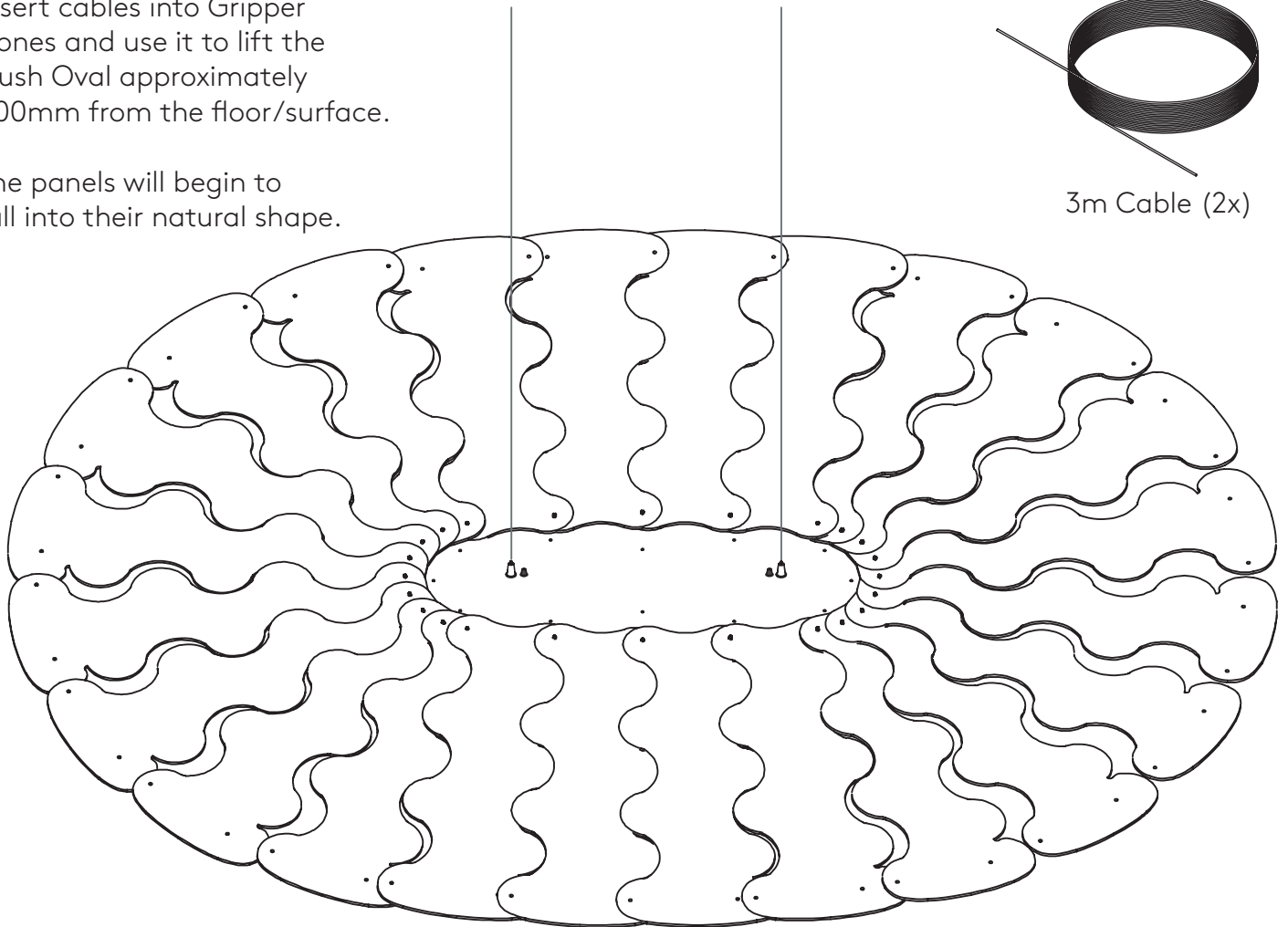
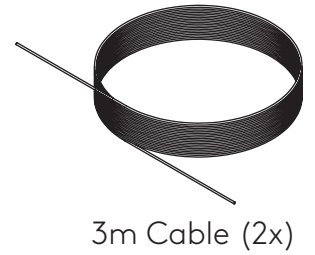

IMPORTANT:
ENSURE YOU ONLY USE THE 2x
STEEL CABLES TO
LIFT THE OVAL HUSH LIGHT

Use the folded cardboard pillar that was in the box to prop it up.

**DO NOT LIFT USING
ELECTRICAL WIRE**

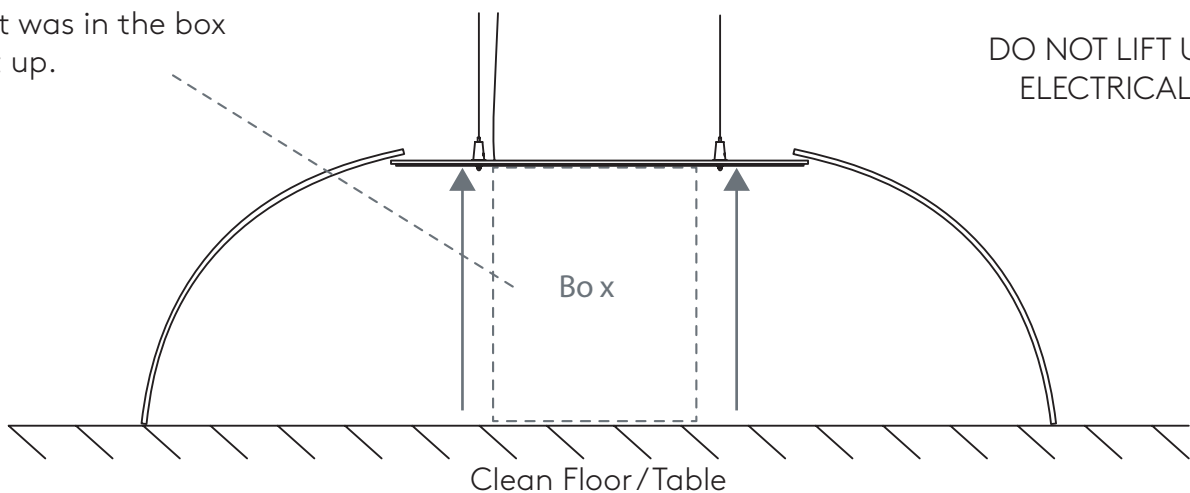

Step 6A - Weaving of Panels - Exploded Detail

Bold Lines indicate the 'Ear' that sits on the outside of the Hush Round.
This weaving pattern is essential to lock the shape together

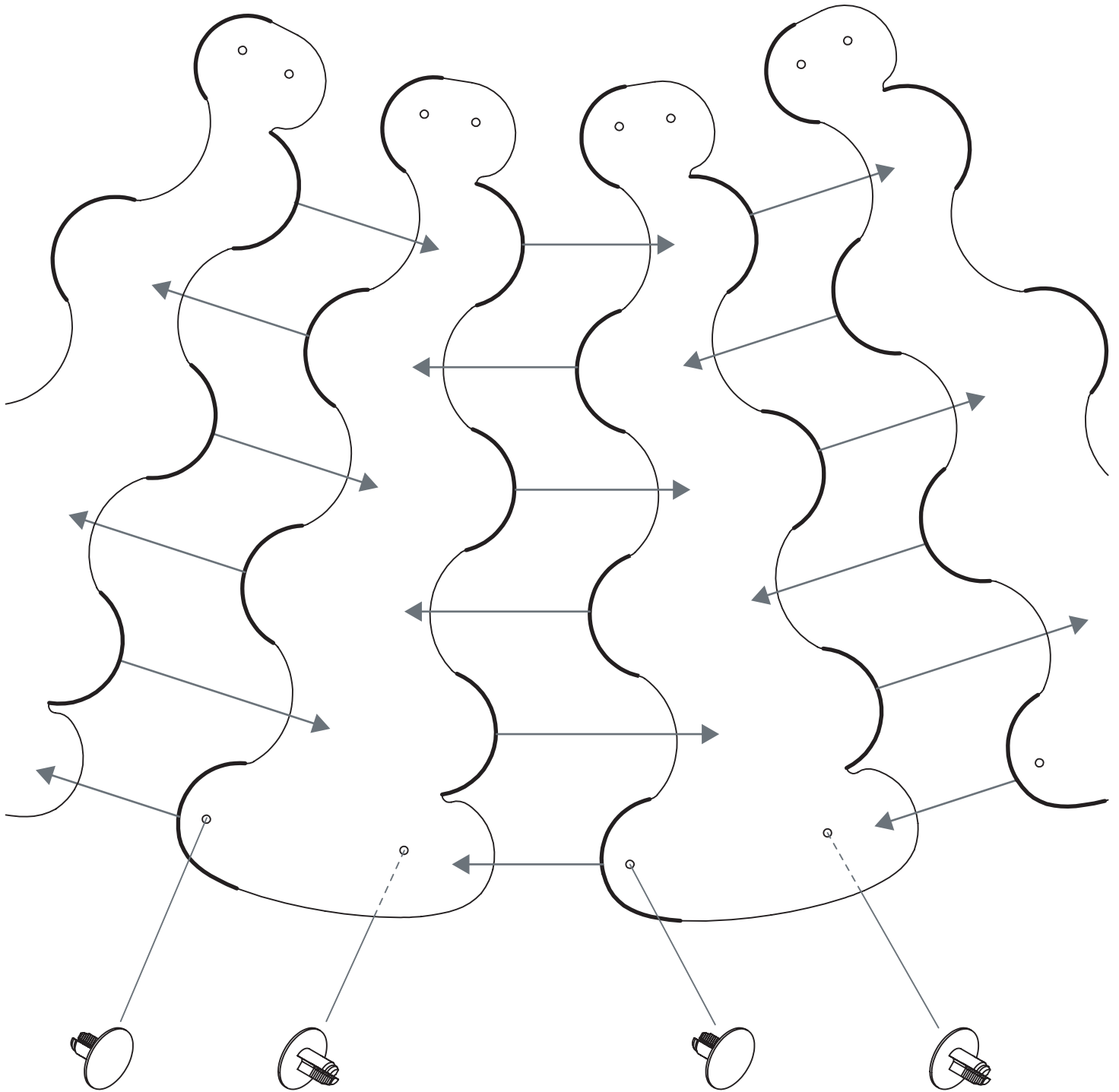

Once two panels are woven together, use two of the shorter Ratchet Rivets (13mm) to lock them together

HUSH OVAL E26

Designed by David Trubridge
(1018-D)

PLN GROUP

Step 6A - Weaving of Panels - Finished Detail

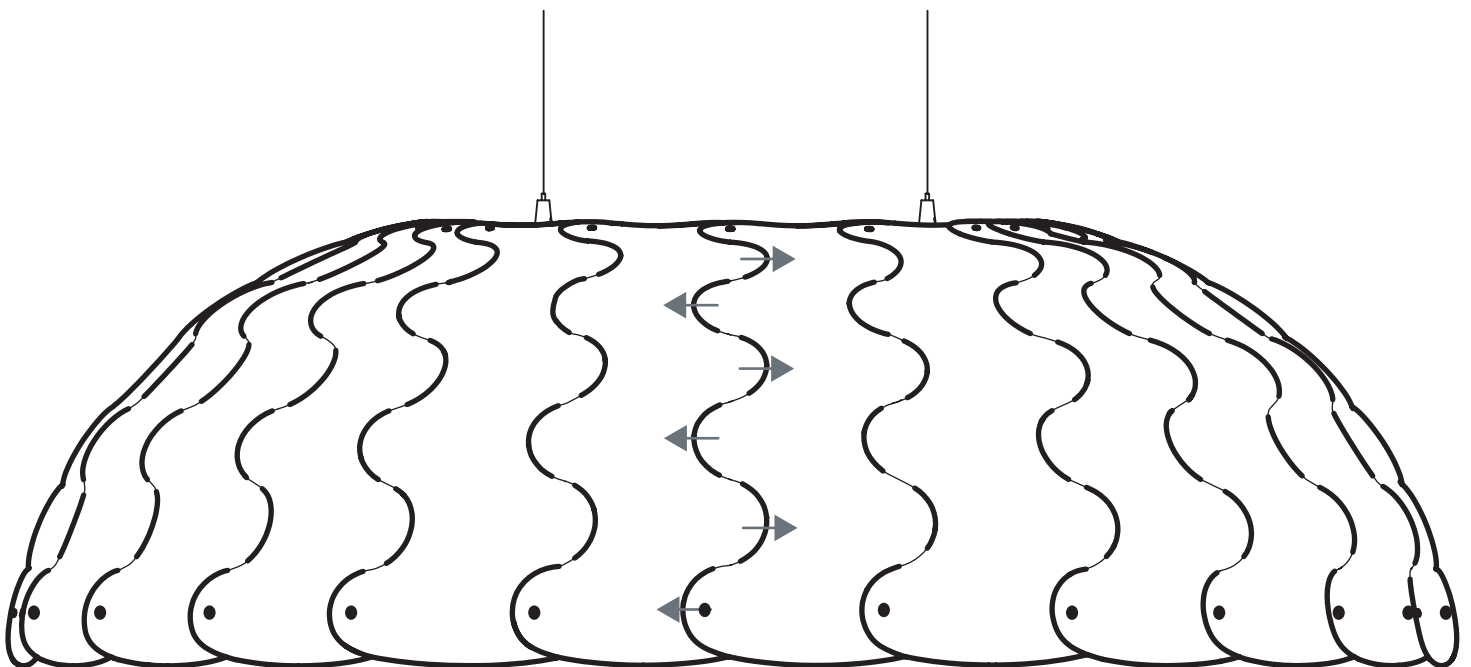
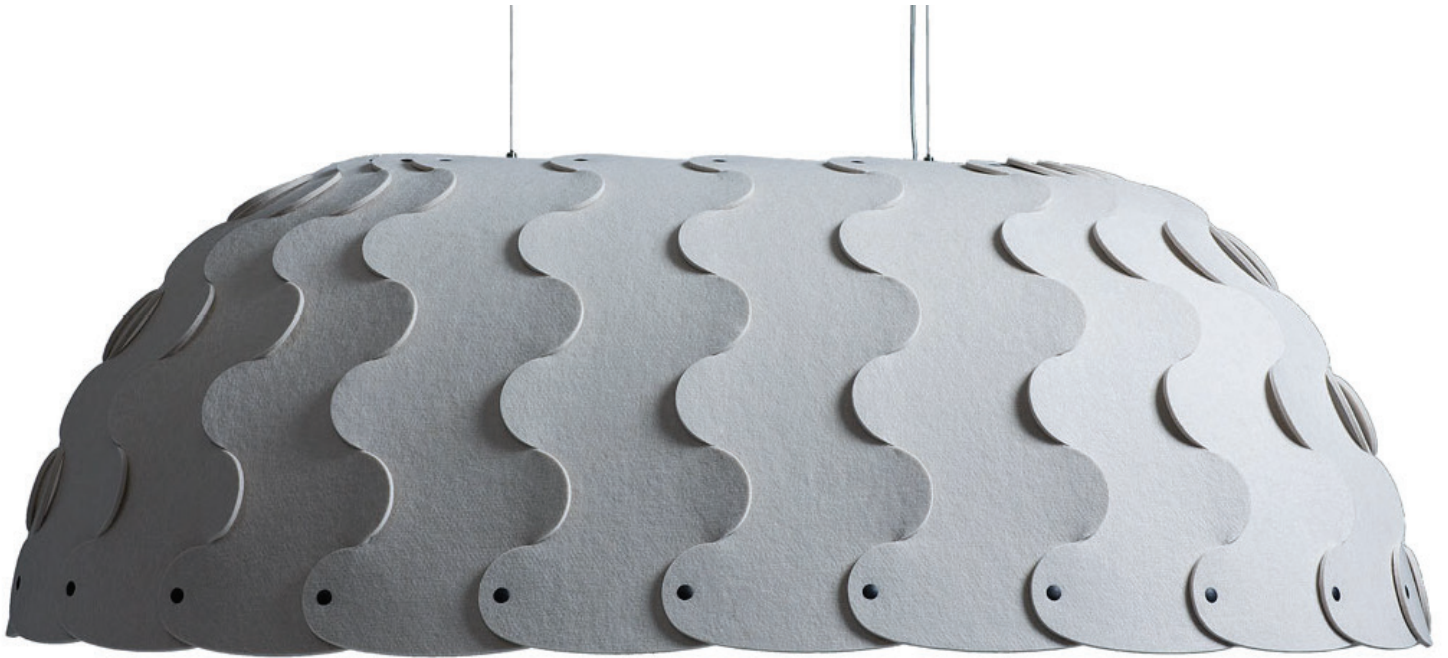

Bold Lines indicate the 'Ear' that sits on the outside of the Hush Oval.
This weaving pattern is essential to lock the shape together

HUSH OVAL E26

Designed by David Trubridge
(1018-D)

PLN GROUP

Step 7 - Height Adjustment and Levelling

Ceiling Mounting Point.

If installing into wood use a countersunk timber screw (not supplied) to affix cone grip to ceiling.

If installing into concrete use countersunk anchor bolt (not supplied) to affix cone grips to ceiling.

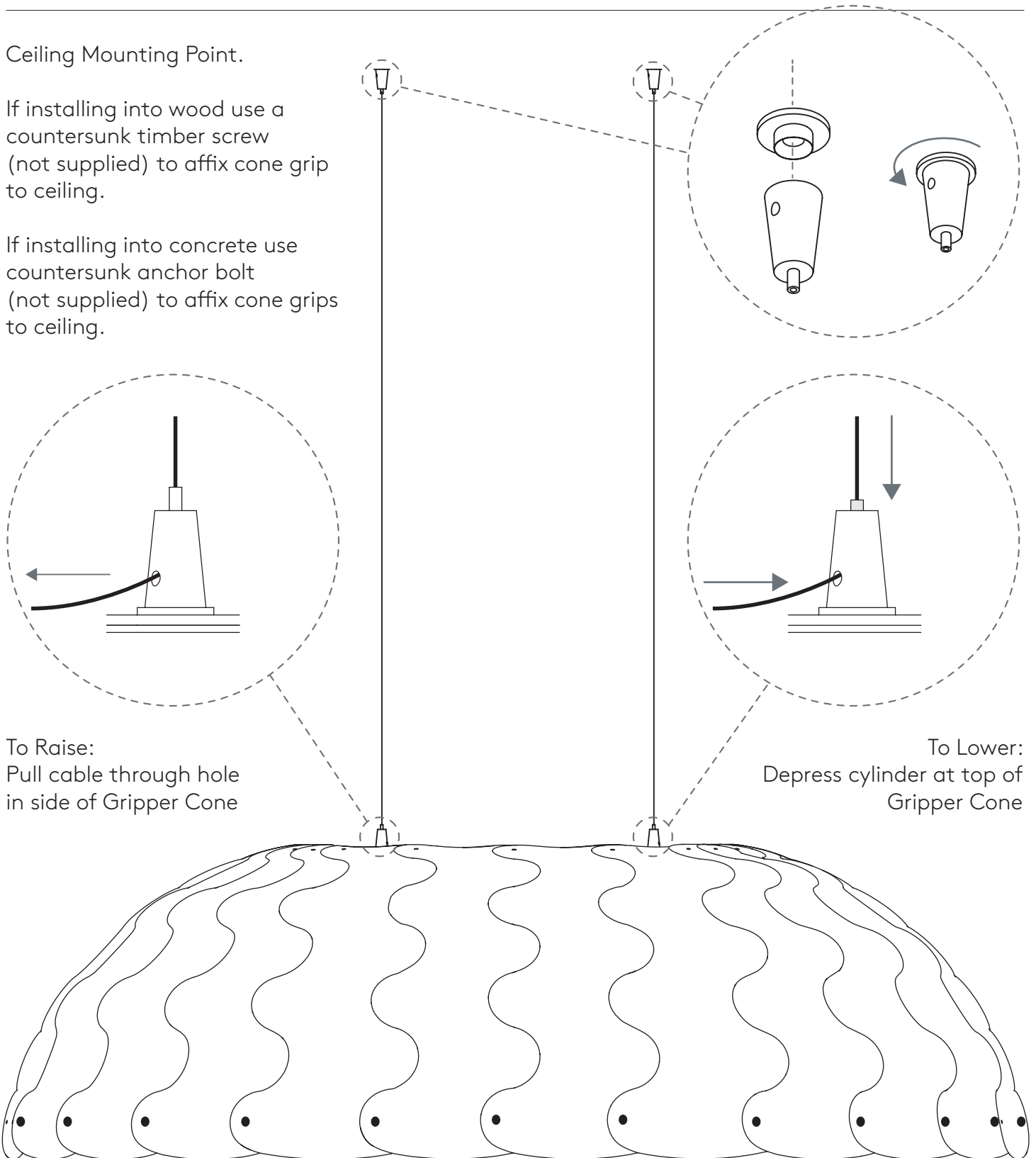

HUSH OVAL E26

Designed by David Trubridge
(1018-D)

Step 8 - Electrics, Suggested LED driver placement with hanging ceiling

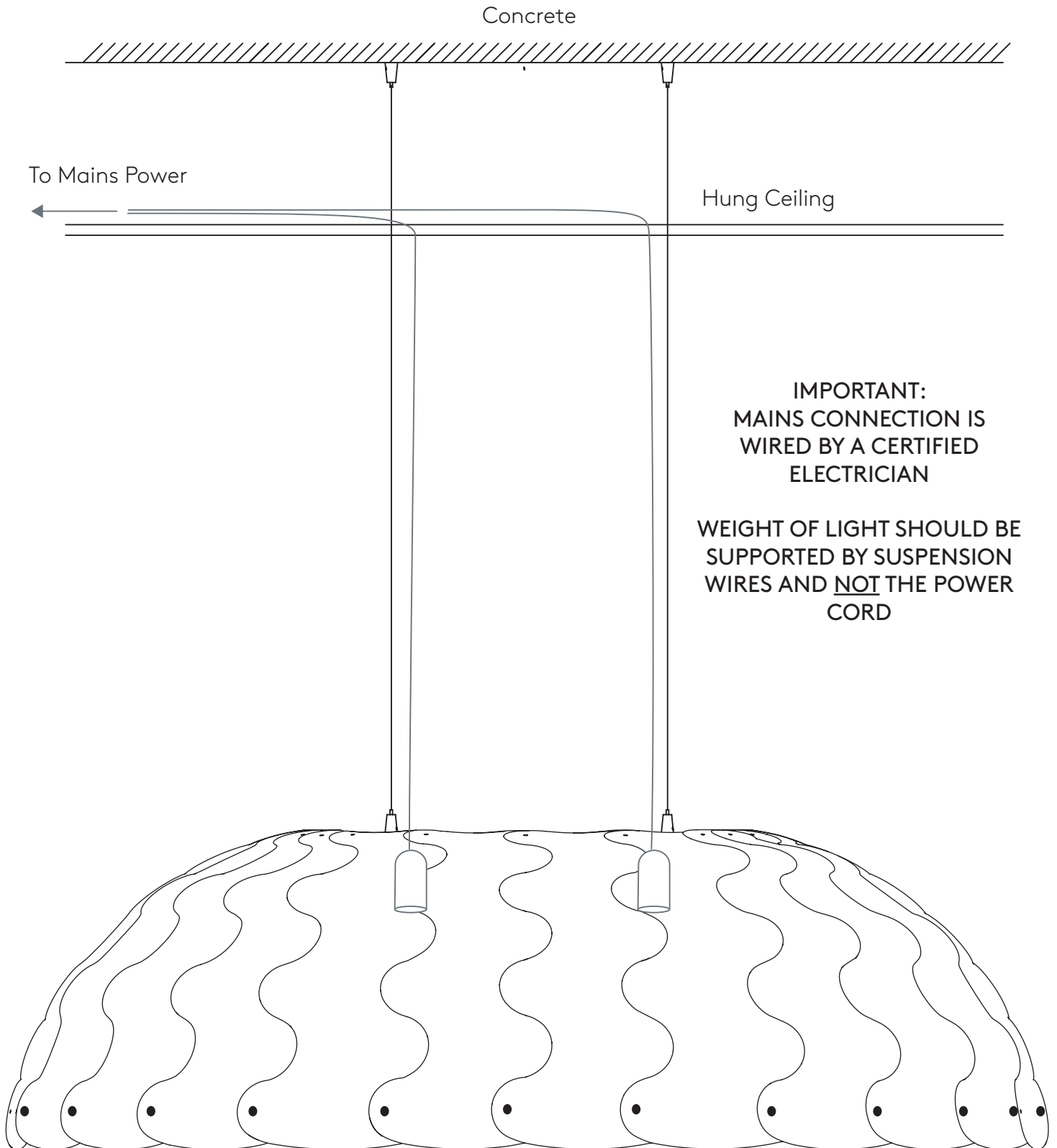

HUSH OVAL E26

Designed by David Trubridge
(1018-D)

Appendix: Top Panel Sub Assembly

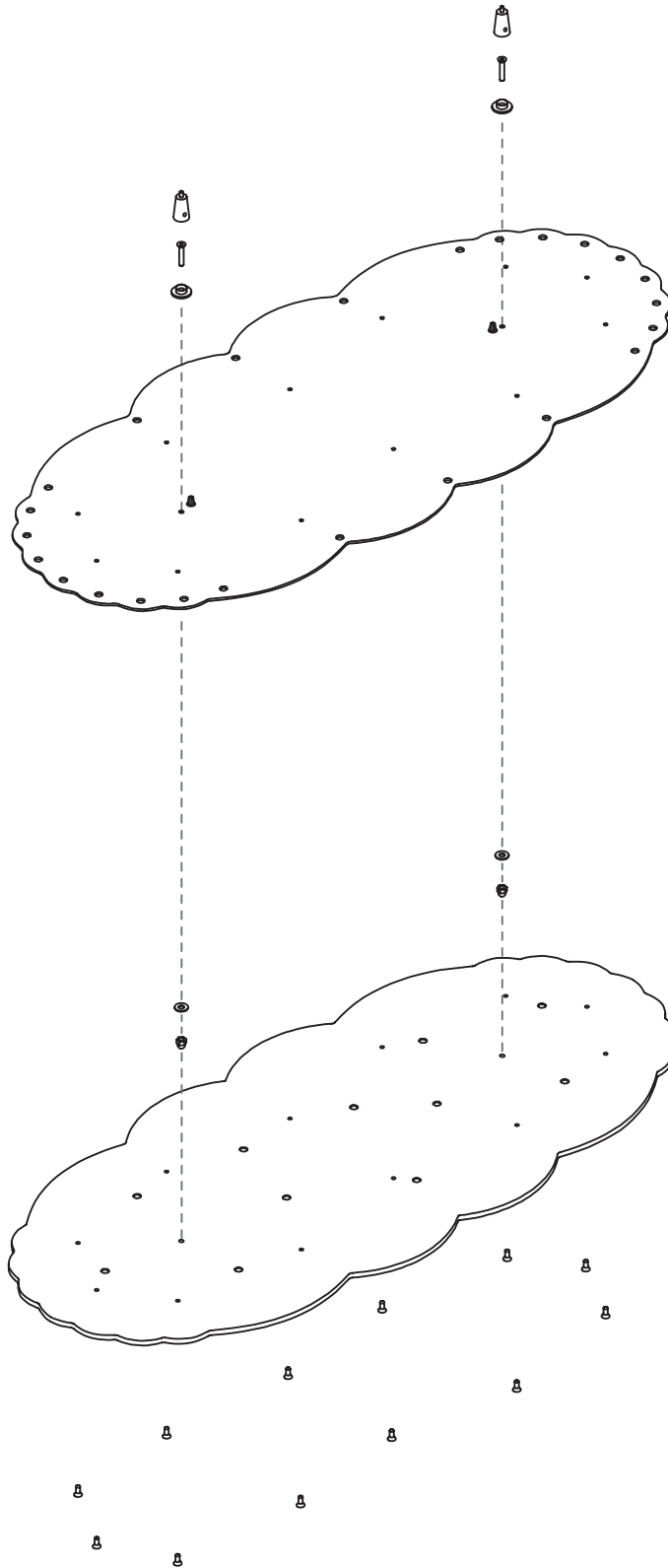

2x Gripper Cones
2x M5 20mm Screws

Aluminium Panel

2x Washers
2x Cap Nuts

Felt Panel

12 x 12mm Screws

Exploded View